

SolidCAM + SolidWorks

The complete integrated Manufacturing Solution

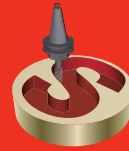

SolidCAM

The Leaders in Integrated CAM

HSM

SolidCAM HSM Module

```
T2 M6 ("TOOL 2 - DIA 24.0")
M01
G54 G1
G22 N=8001
G22 N=8000
G00 X87.851 Z170 Y47.399 S1000 M13
G003 C3-1
G0141
G022 N=9002 ("*****5X-selected-faces1-T2*****")
G040
G003 C3-1
M03
G74 Z-1 L1
G174 X-700 Y-520 L1
G07 L1-1
G003 C3-1
G4 M30
M0001
M001
G0 E101-D (Y) E102-D (Z) E103-D (A) E111-D (B) E112-D (C) E113-D E105
M0180-D E181-D E182-D
M0002
M0002 0
N5 ("*****5X-SELECTED-FACES1-T2*****")
N6 G0 X87.851 Y47.399 Z130 C0 B16.367
N7 Z121.585
N8 X85.825 Y44.417 Z103.849
N9 G1 X85.6 Y44.086 Z101.99 F33
N10 X85.597 Y43.987 Z102.008
N11 X85.53 Y43.756 Z102.049
N12 X85.434 Y43.542 Z102.099
N13 X85.304 Y43.344 Z102.187
N14 X85.149 Y43.171 Z102.16
N15 X84.982 Y43.026 Z102.139
N16 X84.741 Y42.915 Z102.219
N17 X84.514 Y42.839 Z102.259
N18 X84.278 Y42.802 Z102.239
N19 X84.038 Y42.804 Z102.242
N20 Y42.799
N21 X82.904 Y42.804 Z102.251 C09.126 B16.533
N22 X81.81 Y42.888 Z102.26 C09.842 B17.831
N23 X80.897 Y43.083 Z102.266 C06.728 B16.16
N24 X79.025 Y43.284 Z102.269 C04.621 B14.51
N25 X77.295 Y43.083 Z102.266 C02.514 B12.85
```



Advanced 3D Mill and High Speed Machining Module - Integrated in SolidWorks

SolidCAM HSM is a very powerful and market-proven advanced 3D Mill and high-speed-machining module for 3D parts, aerospace parts and molds, tools and dies. The HSM module offers unique machining and linking strategies for generating advanced 3D Mill and high-speed toolpaths.

SolidCAM's HSM module smooths the paths of both cutting moves and retracts wherever possible to maintain a continuous machine tool motion – an essential requirement for maintaining higher feedrates and eliminating dwelling.

With SolidCAM HSM module retracts to high Z levels are kept to a minimum. Angled where possible, smoothed by arcs, retracts do not go any higher than necessary – thus minimizing aircutting and reducing machining time.

The result of the HSM module is an efficient, smooth, and optimal toolpath. This translates to increased surface quality, less wear on your cutters, and a longer life for your machine tools.

With demands for ever-shorter lead and production times, lower costs and improved quality, SolidCAM's HSM Module is a must in today's machine shops.

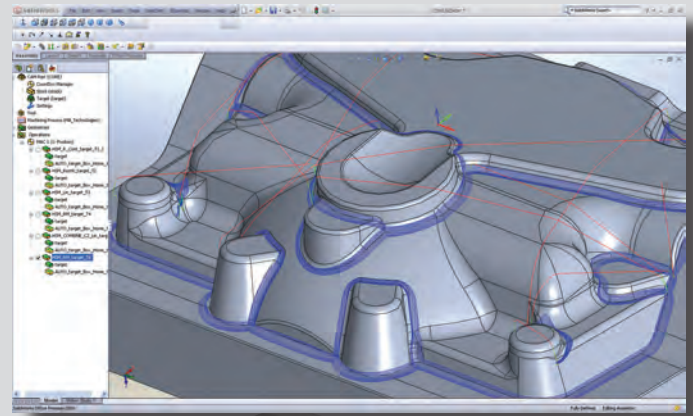

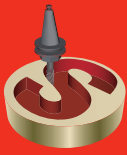

HSM Roughing Strategies

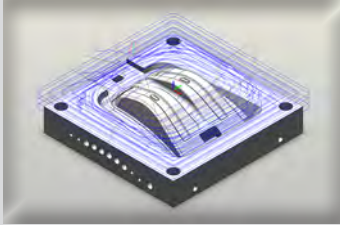

CONTOUR ROUGHING

Contour Roughing is the main strategy for clearing large volumes of material effectively. A series of offset passes are generated at specified Z-depths and are automatically calculated to remove the maximum amount of material without leaving upstands. The depth of cut automatically adapts, ensuring the machining of flat faces. Either helix or profile ramping entry is used. Smoothing arcs are created automatically, both in the passes and linking moves, eliminating dwelling, improving effective cutting feedrates and tool life.

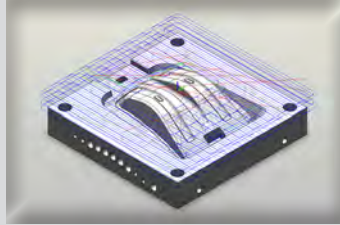

HATCH ROUGHING

The Hatch Roughing strategy efficiently removes large material volumes by linear tool motions, including material removal at corners. Machining is performed at automatically defined Z levels that ensure removing maximum material efficiently. Machining depth is automatically calculated to ensure efficient milling at Horizontal areas between the calculated Down-steps. This option creates smooth tool motions thus speeding up milling and preserving tool life.

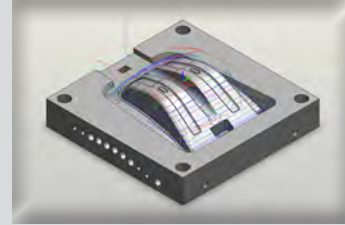

REST ROUGHING

Rest Roughing is achieved by following the work of a big tool with a smaller tool, in areas not cleared by the previous operation. The InventorCAM HSM module uses an updated stock model of the remaining material to avoid air-cutting. For big parts you can perform more than one rest roughing operation, with decreasing tool sizes. Rest Roughing can also be used when machining castings by trimming the passes to the cast surface model, with appropriate stock allowance.

« SolidCAM HSM is a powerful solution for all users who need advanced 3D Mill and high speed machining capabilities... »

HSM Finishing Strategies

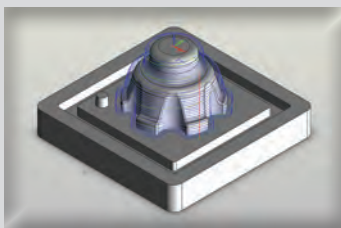

CONSTANT-Z MACHINING

Constant-Z machining passes are generated from a set of surface contours which describe the shape of surfaces at different z-heights - like horizontal slices through the geometry. This is the best strategy for semi-finishing and finishing of steep walls. By limiting the Constant-Z passes to contact angles between 30 to 90 degrees, the steeper areas are machined, leaving the shallower area for more appropriate strategies.

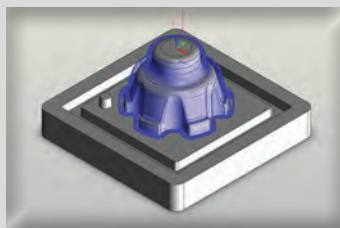

HELICAL MACHINING

Helical machining passes are generated from a set of surface contours which describe the shape of surfaces at different z-heights. The profiles are joined in a continuous descending ramp that follows the shape of the model. Helical passes are generally used for semi-finishing and finishing. Helical passes are best suited for surfaces whose angles are between 30 and 90 degrees.

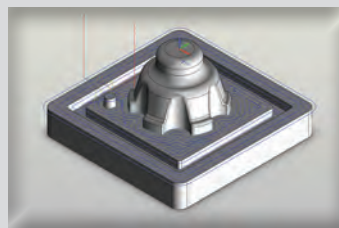

HORIZONTAL MACHINING

Horizontal Machining strategy automatically detects all the flat areas of the part and clears them with an offsetting path at the z-level of each area, utilizing similar smoothing characteristics as roughing. Linking is also similar to roughing with helix and profile ramping entries and smooth linking motions. If the user requires to machine these flat areas with more than one pass, any number of Z-axial offset passes can be added.

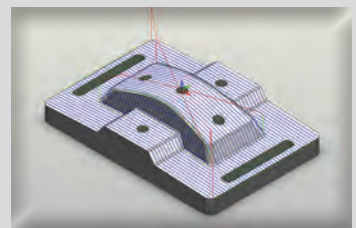

LINEAR MACHINING

Linear Machining is one of the most widely used finishing strategies. Linear passes are typically used to semi-finish cusps from roughing operations and to finish shallow areas. The passes are parallel in the XY-plane and follow the surface in Z-direction. You can choose their angle as well as their stepover in the horizontal direction. Cross linear-paths, at 90 degrees to the linear path, are used to finish the whole part.

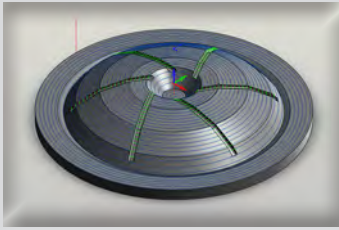

RADIAL MACHINING

Radial machining provides the user with the ability to machine radial parts. Machining converges to a central point with the ability to stop short of the center of the radial passes, where they become very dense. This strategy is ideally suited for use on areas that include shallow curved surfaces and circular areas, using contact angles between 0 – 40 degrees.

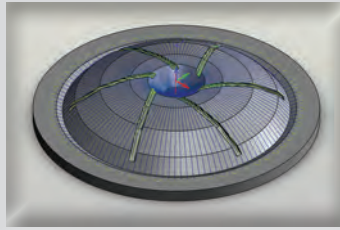

SPIRAL MACHINING

Spiral machining creates a spiral toolpath from a given focal point, while keeping constant contact between the cutter and workpiece as it machines within a given boundary. A stepover defines the spacing between each coil of the pass. The focal point of the detail to be machined with spiral or radial passes is located automatically, or can be determined by the user.

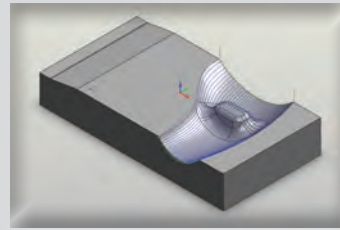

MORPHED MACHINING

Morphed machining controls the toolpath using flow boundaries and direction profiles. Morphed passes flow across the surface in a close-to-parallel formation with the shape and direction of the passes dictated by the boundaries around them. Each path echoes the shape of the one before and takes on some characteristics of the one after, thus gradually changing shape.

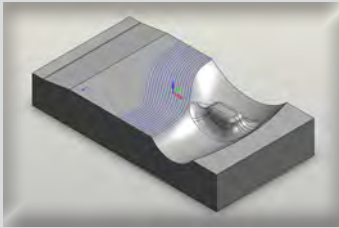

OFFSET CUTTING

Offset Cutting calculates the toolpath based on a defined boundary, defined distance to either one or both sides of the boundary and at a constant step over. The toolpath can be parallel to the boundary in a to/from manner, or perpendicular to the boundary. Offset Cutting is used for machining up to the boundary of a wall or open cavity.

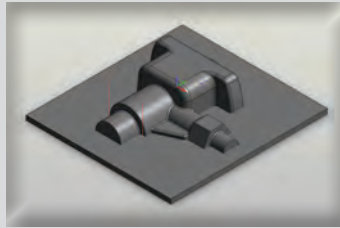

BOUNDARY MACHINING

A Boundary pass is created by dropping the cutter onto the surface and running it along a single boundary or a set of boundaries to produce the effect of engraving. It can be applied for engraving text, chamfering along a profile or of mold tool runner detail. Negative machining thickness can be used to machine at a constant depth below the surface being machined.

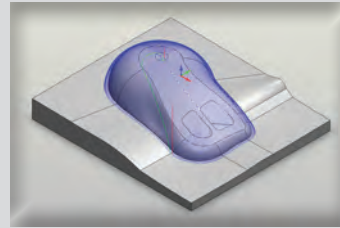

3D CONSTANT STEPOVER

3D Constant-stepover finishing strategy maintains a constant, equidistant stepover from one toolpath pass to the next, irrespective of the slope angle of the part. It creates 3D passes that are at a constant distance from each other along the surface of the part, by offsetting inwards along the surface. This strategy can be applied within any boundary or to the whole part.

M S H

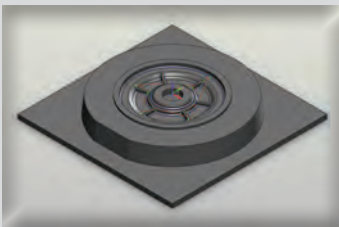

PENCIL MILLING

The Pencil milling strategy creates tool paths along internal corners and fillets with small radii, removing material that no other strategy can reach. The pencil milling routine is used to finish corners which might otherwise have cusp marks left from previous machining operations. This is ideal for machining into corners where the surface radius is the same as the cutter.

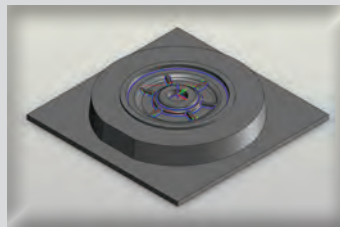

PARALLEL PENCIL MILLING

Parallel pencil milling is an extension to pencil milling where the user can determine the number and step-over of multiple-passes, either side of the pencil tool-path. This is particularly useful when the previous cutting tool has not been able to machine all the internal corner radii to size. These multiple passes will machine from the outside in to the corner, creating a good surface finish.

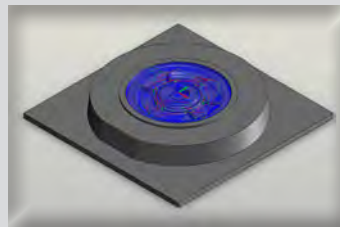

3D CORNER OFFSET

3D Corner offset machining is similar to constant stepover machining. However, rather than start from an outside boundary and work in towards the center, a set of pencil passes are created at the corners of the part. Starting from these corner passes, a tool path that maintains an equidistant surface finish is generated following the 3D form, towards the edges of the part.

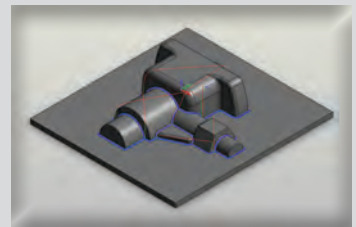

REST MACHINING

While pencil milling of vertical corners can cause both the flute of the cutter and the radius to be in full contact with the material, creating adverse cutting conditions, Rest Machining strategy picks the corners out from the top down resulting in better machining technique. Steep and shallow areas are both machined in a single toolpath with different rest machining strategies.

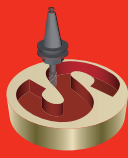

SolidCAM
The Leaders in Integrated CAM

HSM

SolidCAM HSM

The SolidCAM HSM module features several enhancements to CAM technology that make high-speed operations possible, including: avoiding sharp corners in the tool path, ensuring constant tool-part contact as much as possible, reducing air-cutting and generating smooth and tangential in/out leads.

Any HSM 3D machining strategy can be controlled by specifying the surface slope-angle to be machined or by specifying the machining boundary. SolidCAM HSM module provides a comprehensive set of boundary creation tools, including Silhouette boundaries, Cutter Contact Area boundaries, Shallow boundaries, Theoretical Rest Area boundaries, Rest Area boundaries and User-defined boundaries.

SolidCAM HSM module is a powerful solution for all users who need advanced 3D Mill and high speed machining capabilities. It can also be used to improve the productivity of older CNC machines with reduced air-cutting and smoothing arcs that maintain continuous machine tool motion.

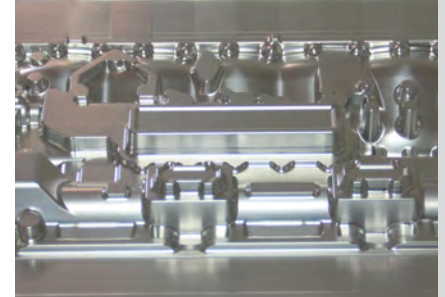

SolidCAM+SolidWorks

Gold-certified SolidWorks Integration and Associativity

With the single-window integration of SolidCAM in SolidWorks, all machining operations can be defined, calculated and verified without leaving the SolidWorks assembly environment. All 2D and 3D geometries used for machining are fully associative to the SolidWorks design model. In a single CAM-Part, several SolidWorks Assembly configurations can be used. Each configuration can represent an independent state or production step of a workpiece.

When the geometry used to define a machining operation is changed in the SolidWorks design, SolidCAM enables the user to automatically synchronize all machining operations with the updated geometry. The full associativity to the SolidWorks design model reduces errors when the model changes and facilitates the process where updates are received for models already machined.

With SolidWorks setting the standard for mainstream CAD systems and SolidCAM's seamless single-window integration in SolidWorks - any size organization can reap the benefits of the combined SolidWorks and SolidCAM solution.



About SolidCAM

Founded in 1984, SolidCAM provides manufacturing customers with a full suite of integrated CAM software modules in SolidWorks for 2.5D Milling, 3D Milling, High Speed Machining, Multi-sided Indexial 4/5 axes Milling, Simultaneous 5-axes Milling, Turning, Mill-Turn up to 5-axes and Wire EDM.

SolidCAM has the Certified Gold Product status from SolidWorks and provides seamless, single-window integration and full associativity to the SolidWorks design model. The hallmarks of SolidCAM are its ease of use, combined with its powerful functionality and customized post processors that generate efficient G-Code.

SolidCAM is used in the mechanical manufacturing, electronics, medical, consumer products, machine design, automotive and aerospace industries, mold, tool and die and rapid prototyping shops.

SolidCAM has today more than 13,500 seats installed in industry and education. CIMdata, the leading worldwide strategic consultancy company, has named SolidCAM, in the "Cimdata NC Software Market Assessment Report", as the consistent growth leader in CAM over the last five years, with annual growth rates in the +30% range.



www.SolidCAM.com

© SolidCAM Ltd. All rights reserved.
All brand and trade names are property of their respective owners.